

IZABELA KOWARSKA*, JAKUB KORTA*, KRYSZTOF KUCZEK**, TADEUSZ UHL*

HYBRID MODELLING OF AN URBAN BUS

SUMMARY

Sophisticated virtual prototyping methods have become a standard in the modern vehicle design process. Unfortunately, in many cases automobile manufacturers (in particular bus manufacturers) still do not take advantage of numerical design techniques, basing instead on intuition and experience. In this paper hybrid modelling of an urban bus is presented. A hybrid bus model links different types of modelling that can be used to perform a wide range of virtual analyses of vehicle static and dynamic behaviour. The major objective of development and usage of a complex model is to reduce a time and cost of vehicle design process improving vehicle quality at the same time. The main advantage instead is a possibility to exploit a model for different performances of vehicle subsystems. A hybrid model representing real vehicle behaviour consists of three modelling techniques commonly used in automotive industry: multibody modelling, finite element modelling and multi-port (block) modelling. A full model has been developed via commercial software which ensures its availability among automotive engineers.

Keywords: hybrid modelling, urban bus model, vehicle dynamics

HYBRYDOWE MODELOWANIE AUTOBUSU MIEJSKIEGO

Zaawansowane metody wirtualnego prototypowania są standardem w nowoczesnym procesie projektowania pojazdów. Niestety, w wielu przypadkach producenci pojazdów (a w szczególności autobusów) nadal nie odnoszą korzyści z numerycznych technik projektowania, opierając się raczej na intuicji i doświadczeniu. W niniejszym artykule zaprezentowano podejście hybrydowe w modelowaniu pojazdów samochodowych, opisane na przykładzie autobusu miejskiego. Model hybrydowy łączy różne typy modeli numerycznych, które są wykorzystane w szerokiej gamie wirtualnych analiz zachowania statycznego i dynamicznego pojazdów. Głównym celem opracowania i zastosowania kompleksowego modelu jest ograniczenie czasu i kosztów procesu projektowania pojazdów wraz z jednoczesną poprawą ich jakości. Główną zaletą natomiast jest możliwość wykorzystania modelu do analizy różnych podsystemów pojazdów. Model hybrydowy łączy techniki powszechnie stosowane w przemyśle motoryzacyjnym: modelowanie mechanizmów wielocłonowych, modelowanie metodą elementów skończonych i modelowanie blokowe (wieloportowe), które w połączeniu tworzą w pełni wyposażony model odzwierciedlający rzeczywiste zachowanie pojazdu. Pełny model został opracowany z zastosowaniem komercyjnego oprogramowania, które zapewnia jego dostępność wśród inżynierów z branży motoryzacyjnej.

Słowa kluczowe: modelowanie hybrydowe, model autobusu miejskiego, dynamika pojazdu

LIST OF ABBREVIATIONS

Abbreviation	Signification
ABS	Anti-lock Braking System
AGH UST	AGH University of Science and Technology
CAD	Computer- Aided Design
CAE	Computer- Aided Engineering
EBD	Electronic Braking Force Distribution
ECAS	Electronically Controlled Air Suspension
FEA	Finite Element Analysis
OEM	Original Equipment Manufacturers

1. INTRODUCTION

Very fast development of CAD/CAE (Computer-Aided Design and Computer-Aided Engineering) tools (Lee 1999) resulted in an increasing interest in virtual prototyping among automotive manufacturers. The main reason for using more and more often vehicle numerical models instead of real

prototypes is a necessity of cost reduction, shorter time to market and increase in quality of new vehicles due to enormous competition and continuously growing requirements and standards. Following (Donders 2008) today automotive OEMs (Original Equipment Manufacturers) are focused on "Design Right First Time" in case of which only single prototype should be prepared. All important decisions should be taken and engineering problems should be solved in the early design stage based on numerical simulations. Such an approach guarantees low development costs since eliminating the defects and changes made in virtual model are cheaper than in a real prototype (Fig. 1) (Haskins 2006).

Automotive engineers have to deal with great variety of vehicle subsystems (body, chassis, electronic equipment, etc.). It is important to create a single model that can satisfy requirements coming from different automotive departments. However, it is not a trivial task as different vehicle subsystem should be modeled with different techniques. To analyze vehicle dynamic behavior with road interactions taken into account, different vehicle maneuvers and road

* AGH University of Science and Technology, Faculty of Mechanical Engineering and Robotics, Department of Robotics and Mechatronics, Krakow, Poland; tuhl@agh.edu.pl

** EC Engineering Sp. z o.o., Krakow

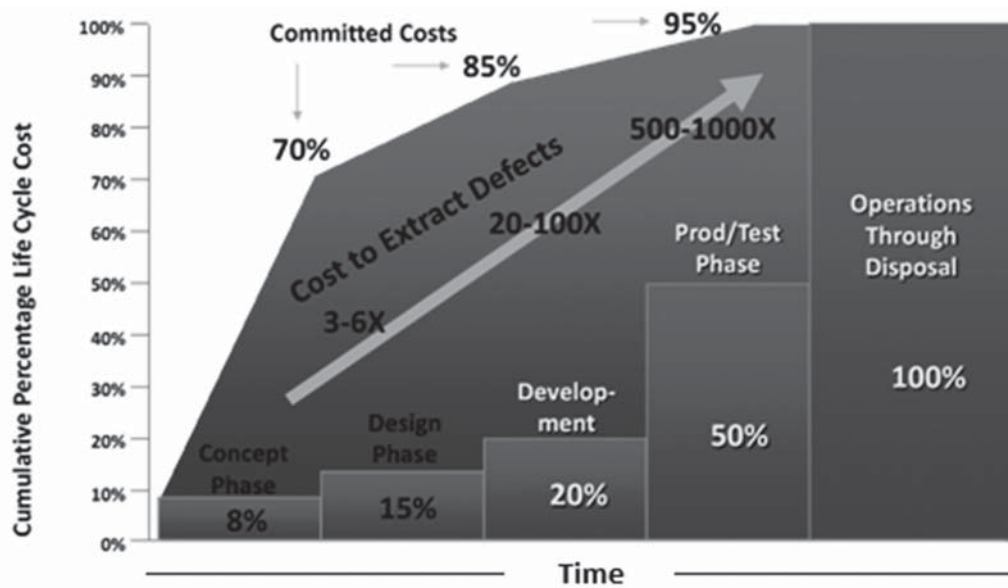

Fig. 1. Lifecycle cost in a different vehicle development stages

conditions should be employed into the model. For instance, to obtain a good compromise between ride and handling, a multibody model of a rigid body interconnected with flexible components can be used (Prado et al. 2001, Goncalves and Ambrosio 2005). One of the best tools to analyze vehicle crashworthiness, NVH, static or dynamic stiffness is the finite element method (Babu et al. 2012, Svida et al. 2007).

In most cases it would be more efficient to have one integrated model to analyze vehicle behavior tested in conditions equivalent to the reality.

While car models are more and more complex to ensure more accurate results from numerical simulations, bus manufacturers are still one step behind. Providing a reliable urban bus model is even more desired than in case of the passenger car. This is due to the fact that production of a bus prototype is far more expensive.

Urban buses are commonly used nowadays, especially in big agglomerations where traffic jams significantly decrease the traveling speed of private vehicles. In such a case, public transport is the most suitable way to reach a destination (Litman 2012). This makes a great demand for urban buses. However, high competition, increasing passenger requirements for comfort and accessibility and growing government demands for safety and environment protection force bus manufacturers to increase the quality of their products at the same time. However, many of them are still basing only on experience and intuition instead of virtual analyses, which is caused by the lack of sophisticated and validated models.

In order to satisfy bus manufacturers' needs, urban bus hybrid model has been developed. Virtual assessment links different modeling methods and can be used to simulate, analyze and finally optimize city bus behavior under different

operational conditions. The most important benefit of such a hybrid model application is the possibility of simulating the vehicle under complex loads during the ride, which is unattainable using standard numerical methods. Excitation resulting from pavement irregularities, bus maneuvers and vehicle intelligent systems interaction generate a complex load scenario, difficult to mimic in a standard FE simulation. Another important advantage of using this model is time and money saving. For example, nowadays adjusting bus suspension parameters to increase traveling comfort takes about a week of real test rides, which is very expensive due to fuel consumption and a number of people involved. With the application of the proposed hybrid model and optimization procedure, the same parameters can be optimized in about one day with incomparably smaller cost of used computer and work of one person.

2. URBAN BUS MODEL AND ANALYSIS

The hybrid urban bus model has been developed in the LMS Virtual.Lab simulation suite which enables engineers to effectively analyze and optimize real-life performance of mechanical and mechatronical systems, long before physical testing. LMS software is the base platform for the described analyses (Fig. 2). It integrates different model subsystems and carries out the simulations.

The numerical model itself consists of:

- Rigid multibody chassis model,
- Flexible bus superstructure,
- On-board systems.

Each element will be described in separate chapter.

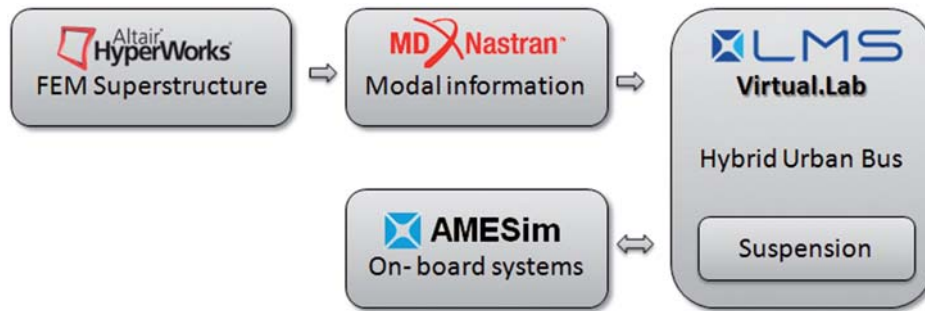

Fig. 2. A hybrid urban bus model

3. THE COUPLED RIGID – FLEXIBLE MULTIBODY MODEL

The bus chassis model in Virtual.Lab has been divided into front suspension with Pitman arm steering and rear suspension. Due to the fact that most of the chassis construction elements exhibit high stiffness, the authors decided to represent them in the form of a rigid model, based on CAD files provided by the manufacturer. Detailed geometry description ensured proper mass and inertia properties and center of gravity positions, keeping the computations accuracy within tolerable level. Interacting elements have been linked with proper kinematic joints to ensure required motion.

To minimize computational error, the suspension system has been equipped with six tires, modeled as a Virtual.Lab type “complex tire”. It ensures the possibility to define tire features related to its stiffness and damping (LMS 2012). Applied dampers have been attributed with velocity- force characteristics based on the data provided by the vehicle manufacturer. The air springs have been replaced with a combination of damping and stiffness forces element con-

trolled by the ECAS (Electronically Controlled Air Suspension) system (Fig. 3).

All connections requiring rubber bushing in a real bus have been realized with virtual bushings with force/moment- deformation characteristics supported externally. In contrast to the suspension, bus superstructure is less rigid. For this reason, dynamic behavior of the bus body and its influence on ride test was demanded. The flexible model has been evaluated with FEM model prepared in Altair HyperMesh, calculated with MSC.Software MD.Nastran and imported to the Virtual.Lab multibody model. To reduce the large number of modal coordinates that described bus structure, Craig- Bampton reduction (Eq. 1) has been used.

$$\begin{Bmatrix} u_b \\ u_i \end{Bmatrix} = \Phi_{CB} \cdot \begin{Bmatrix} u_b \\ q \end{Bmatrix} = \begin{bmatrix} I & 0 \\ \Phi_R & \Phi_L \end{bmatrix} \cdot \begin{Bmatrix} u_b \\ q \end{Bmatrix} \quad (1)$$

where u_b – boundary degrees of freedom, u_i – internal dof’s, q – modal dof’s, Φ_{CB} – a Craig-Bampton’s Transformation matrix, Φ_R – rigid body vector and Φ_L – fixed base mode-shapes.

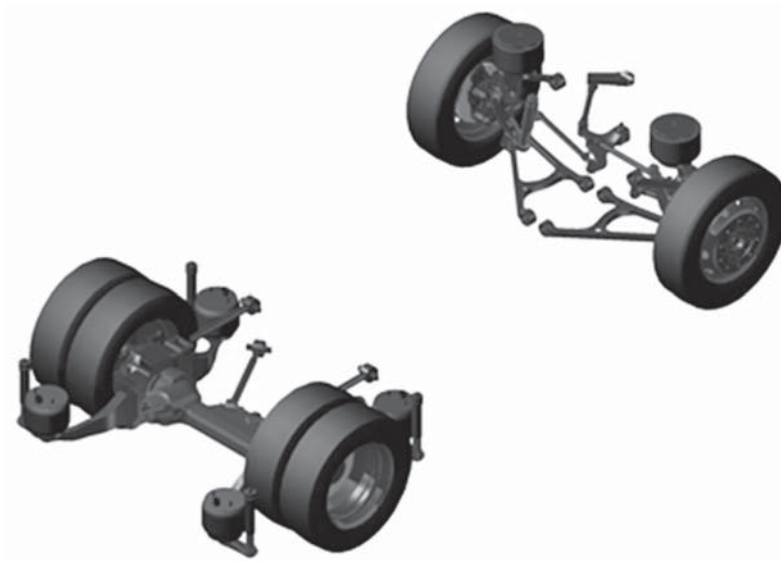

Fig. 3. Suspension multibody model

The compliance of the coupled rigid- flexible model has been evaluated by linking in the multibody software both: rigid and flexible structures, obtaining the model with 135 degrees of freedom and 459 kinematic constrains (Fig. 4).

Equation of motion including flexible superstructure can be written (LMS 2012) (2):

$$\begin{bmatrix} M_r & M_{rf} & \Phi_r^T \\ M_{fr} & M_f & \Phi_f^T \\ \Phi_r & \Phi_f & 0 \end{bmatrix} \cdot \begin{bmatrix} \ddot{q} \\ \ddot{u} \\ \lambda \end{bmatrix} = \begin{bmatrix} Q_r \\ Q_f \\ g \end{bmatrix} \quad (2)$$

where M_{rf} is a system r – rigid, f – flexible generalized mass matrix, q – generalized coordinates so-called rigid coordinates (and its derivatives \dot{q}), u – generalized coordinates (so-called modal) and its derivatives \dot{u} , λ – Lagrange multipliers, Q_{rf} – a vector of generalized forces (r – forces on rigid body coordinates; f – forces on modal coordinates), $\Phi_{r,f}$ is a Jacobian matrix of the constraint equations (r – rigid parts, f – flexible) and g is the constrain acceleration “gamma” term.

4. ABS/EBD AND ECAS

Nowadays, basically all new vehicles are equipped with electronic systems which are designed to facilitate a ride.

Especially among heavy transportation vehicles it is necessary to use the on-board systems. To obtain the best performance while virtual testing, the prepared multibody model has been equipped with two types of the on-board systems:

- ABS/EBD (Anti-lock Braking System/ Electronic Braking Force Distribution) that help to avoid locking of the wheels while braking – for instance on a slippery road (ABS) and provide proper braking force distribution in terms of a load distribution inside a vehicle (EBD) (Fig. 5) (Prochowski and Żukowski 2004).
- ECAS (Electronically Controlled Air Suspension)

Electronic on-board systems have been developed with the LMS Imagine.Lab AMESim.

Multi-port models have been linked with Virtual.Lab and co-simulated (exchanging input/output signals) under Virtual.Lab.

ABS/EBD system consists of ready-to-use block elements from AMESim components library. While braking ABS/EBD system calculates braking forces based on signals containing information about wheels’ angular velocities obtained from multibody solver, outputting the force values back to the base platform keeping tires rolling (Fig. 6).



Fig. 4. Coupled rigid- flexible multibody model

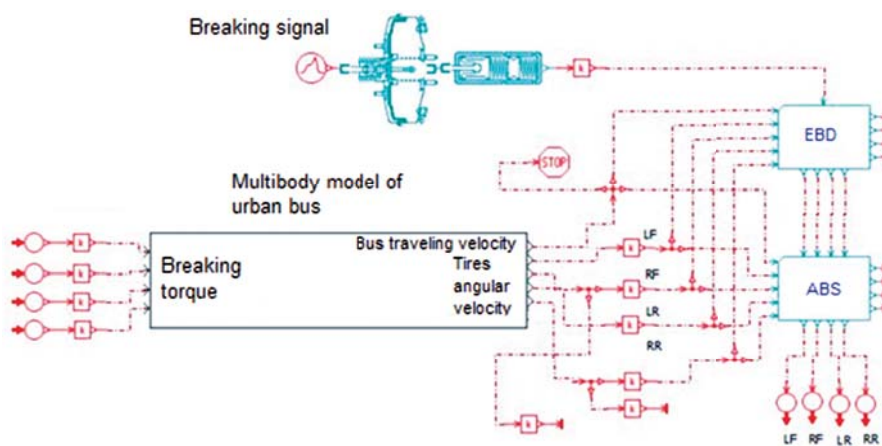

Fig. 5. ABS/EBD on- board systems circuit

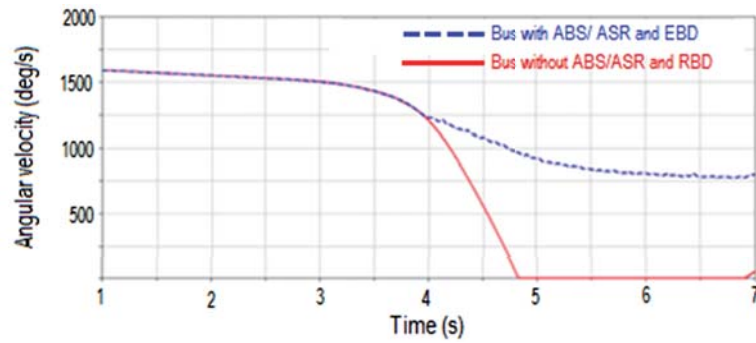

Fig. 6. Breaking performance – comparison of angular velocity of the left wheel: with and without ABS

The employed Electronically Controlled Air Suspension (ECAS) numerical model has been fully developed at AGH UST. It is a pneumatic suspension system used in heavy duty vehicles, e.g. lorries, trailers or buses. It has been used commonly in automobiles since the last decade of the 20th century. The main advantages of using air springs over the standard steel-spring suspensions are (WABCO 1997):

- higher comfort coefficient expressed by smaller deflections and lower natural frequency values,
- possibility of controlling the operational height of the vehicle, by changing the pressure of the medium inside of the volumetric elements,
- kneeling function – in case of busses this function ease getting on and off the vehicle on stops.

The investigated system has been supplied with 6 air cushions, two connected to the front axle and four supporting the rear one. This asymmetry is due to the unequal mass distribution – i.e., engine, gearbox and auxiliary systems are located at the back of the vehicle. The ECAS system has been modeled using the inputs provided by the bus manufacturer. The chart in Figure 7 describes the static deflection of an air spring in function of the payload and internal medium pressure. The data were approximated by means of polynomial regression described in detail in the following paragraph.

The derivation of the mathematical models describing the dynamical behavior of the air cushions can be found in (Hyun-sup and Hyeongcheol 2001, Inseob et al. 2007, Donggil et al. 2009, Hao and Jaecheon 2011). In general, if isothermal process is assumed inside the air spring, its static stiffness can be described by Eq. 3 (Hao and Jaecheon 2011):

$$k_s = \frac{dF}{dx} = P \frac{A_e^2}{V} + (P - P_a) \frac{dA_e}{dx} \quad (3)$$

where F is an applied force, x is a bellows deflection, P is an absolute pressure inside the air spring, P_a is an atmospheric pressure, V denotes internal bellows volume and A_e is an effective area of an air spring (i.e., supported load value divided by P).

Concerning the dynamic characteristic of an air spring, basing on the experimental research by Hao and Jaecheon (2011) also the damping phenomenon was implemented into the suspension model. The authors of (Hao and Jaecheon 2011) have introduced a concept of an equivalent damping coefficient c_{eq} , that is a function of energy losses in a harmonic load-unload cycle E_{loss} , displacement amplitude X_0 and excitation frequency ω , expressed by Eq. (4):

$$E_{loss} = c_{eq} \pi \omega X_0^2 \quad (4)$$

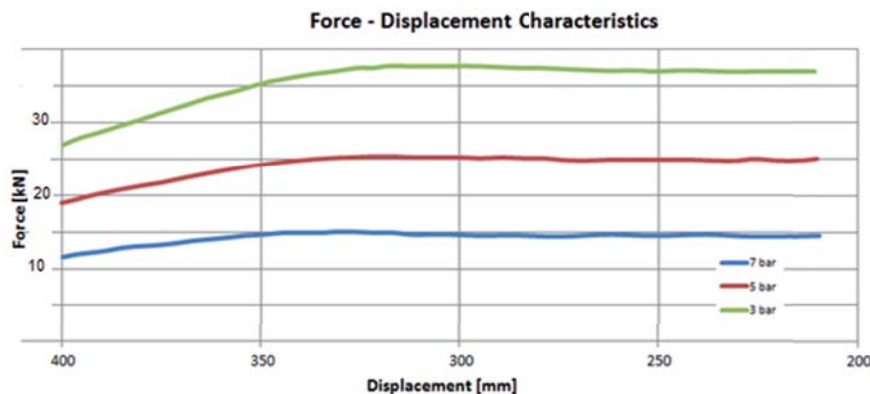

Fig. 7. The static deflection of the modeled air springs (experimental data)

According to this formula, the energy dissipated during the harmonic excitation with a specified frequency is proportional to the damping coefficient of the air cushion. The authors carried out dynamic tests and presented the results on the force-displacement graph, showing the presence of a hysteresis loop. Basing on this data, an appropriate damping coefficient was introduced into the analyzed bus model.

Using the data presented in figure 7, a regression model approximating the static response of each air spring was developed. To fit a curve to the obtained measurement points, linear robust least squares method has been employed. The standard least squares method tends to minimize the squared distance between the regression curve and the provided data points, thus it is sensitive to outliers. To omit that problem, special algorithm was implemented which assigns a weighting factor to every measurement point. The value is inversely proportional to the distance of the measured points from the fitted polynomial curve, thus the influence of the outliers can be minimized. Furthermore, points which are further away than expected are ignored. The error estimator to minimize is expressed by Eq. (5):

$$S = \sum_{i=1}^n w_i (y_i - \hat{y}_i)^2 \quad (5)$$

where w_i is the weighting factor for the squared distance between measured y_i and fitted \hat{y}_i values. Measuring equipment inaccuracies are supposed to be invariant in time, hence the variance of the acquired data should be constant. If this assumption is violated, it is highly probable that the input data set contains some elements of poor quality. The weights w_i are then applied to transform the variances to a constant value.

The approximated data are depicted in figure 8. The obtained force response is a function of pressure and deflection of the air cushion. Because of its strong nonlinear character and for simplification, it was split into two separate regions: force generated by an inflated air spring and force generated by a bump stop, after reaching a critical deflection. The latter is expressed only as a function of bump stop material stiffness. These two separate regression models were then chosen alternately, depending on the continuously measured distance between the upper and the lower air spring housings.

After the data fitting using the described approximation method, the accuracy of the obtained model was controlled. Figure 9 shows the approximation error computed as the relative difference between the measured and the approximated values. The maximal error is about 5.7%, with respect to the measured force values. The accuracy level was satisfactory for the further computations.

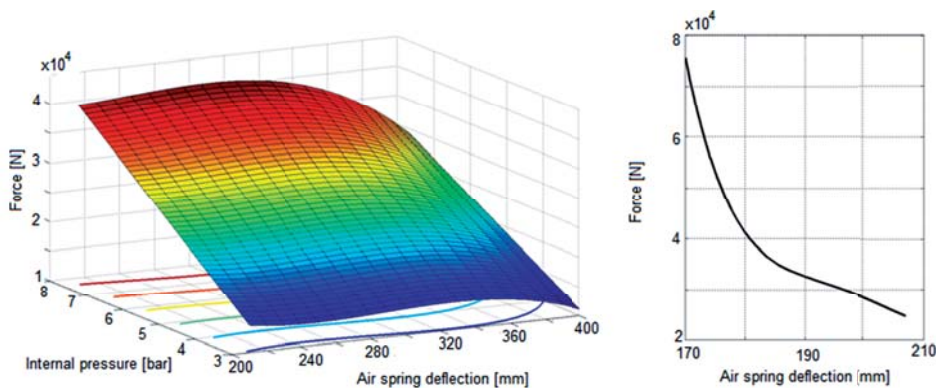

Fig. 8. Measurement data approximation: the inflated air spring (left) and the bump stop (right) characteristics

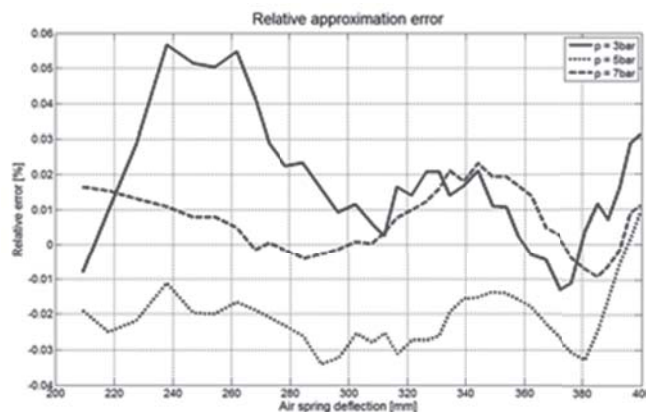

Fig. 9. The approximation errors of the fitted surface

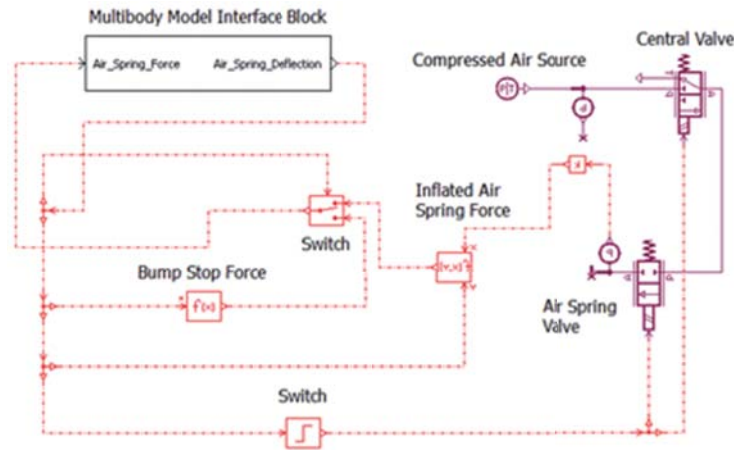

Fig. 10. Block diagram of an air-spring, containing the approximated deflection characteristic

Part of the model representing the considered suspension system implemented into the multibody dynamic simulations is shown in figure 10. The full model consisted of six blocks similar to the one presented in the picture. As described above, the ECAS system is used to control the operational height of the vehicle and its roll and pitch angle instead of anti-roll bar that is used in passenger cars, by modifying pressure in air springs. The system presented in the picture controls the deflection of an air spring and generates an appropriate force, sending that value to the multibody simulation software. If deflection was below the specified value, the signal was switched to the bump stop characteristics. If, on the other hand, operational height was within the allowable tolerances, compressed air flow was cut off and the air-spring was working as an inflated cushion.

By modifying the pressure of the air source, characteristics of the suspension system can be changed. This parameter was one of the design variables in the described optimization process.

5. TESTS

The model described above has been compared with the real structure. This study consisted of recording the bus vibration accelerations while crossing a test track, without any extra load. Vibration accelerations were measured with a set of accelerometers placed on the suspension elements and bus structure. Both real and virtual test rides relied on a ride on special test truck, which was combined from two different surfaces on the left and right its side with obstacles. A constant velocity has been assumed, which means that a period of accelerating and braking was omitted. To obtain the required data, conditions of the analysis were set the same as in the case of experiment, that is the traveling speed was set to 30 km/h. During the experiment, the driver was obliged to keep the velocity constant, but because of many factors (e.g. speedometer inaccuracy, irregular pavement conditions,

etc.) this was only a rough value. For both virtual and experimental test, bus frequency response was estimated.

Nevertheless, as can be seen in figure 11 the results of numerical computations are in great correlation with the data obtained experimentally. The peaks at 11 Hz and their harmonics are the consequence of the form of the test track surface, which was covered by regularly distributed curbstones, and the vehicle speed. Other peaks are caused by structural dynamic response.

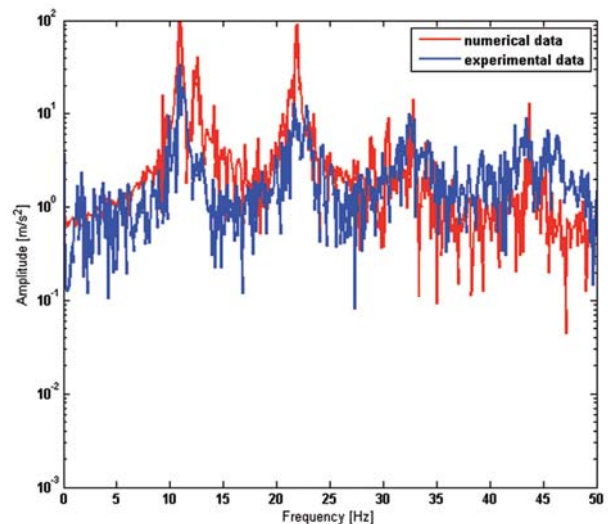

Fig. 11. Comparison between experimental and numerically derived frequency responses of the structure

6. CONCLUSIONS

There is a great variety of CAD/CAE tools that can be used in the automotive industry to decrease time to market of a new vehicle, considerably cut the production cost and to improve vehicles quality simultaneously. Despite the above mentioned advantages, there is very little information on

the subject in the literature. Urban buses have not yet been investigated thoroughly, which opens the way to many improvements that can be obtained cheaply, by means of numerical methods.

The model proposed in this paper is an example of an advanced virtual prototype that can be used in the design process. By the validation process, its accuracy has been confirmed. Hence, the model can be used in the further optimization process. The implementation of the on-board electronic systems (i.e., ABS/EBD and ECAS) provides enhanced performances.

References

- Babu T., Praveen D., Venkateswarao M. 2012, *Crash Analysis Of Car Chassis Frame Using Finite Element Method*. International Journal of Engineering Research & Technology, vol. 1, No. 8, pp. 1–8.
- Donders S. 2008, *Computer-aided engineering methodologies for robust automotive NVH design*. PhD Dissertation, KU Leuven, Leuven.
- Donggil H., Hyunsup K., Hyeongcheol L. 2009, *Height Sensor Fault Diagnosis for Electronic Air Suspension (EAS) System*. Proc. of IEEE International Symposium on Industrial Electronics, Korea, Seoul, July 2009, pp. 211–216.
- Goncalves J., Ambrosio J. 2005, *Road Vehicle Modeling Requirements for Optimization of Ride and Handling*. Multibody System Dynamics, vol. 13, pp. 3–23.
- Hao L., Jaecheon L. 2011, *Model Development of Automotive Air Spring Based on Experimental Research*. Proc. of Third International Conference on Measuring Technology and Mechatronics Automation, China, Shanghai, January 2011, pp. 585–590.
- Haskins C. 2006, *INCOSE systems engineering handbook*. 3rd ed., INCOSE, INCOSE-TP-2003-002-03.
- Hyunsup K., Hyeongcheol L. 2011, *Height and Leveling Control of Automotive Air Suspension System Using Sliding Mode Approach*. IEEE Transactions on Vehicular Technology, vol. 60, No. 5, pp. 2027–2041.
- Inseob J., Hyunsup K., Hyeongcheol L., Sangsoo H. 2007, *Height Control and Failsafe Algorithm for Closed Loop Air Suspension Control System*. Proc. of International Conference on Control, Automations and Systems, Korea, Seoul, October 2007, pp. 373–378.
- Lee K. 1999, *Principles of CAD/CAM/CAE systems*. 1st ed., Addison Wesley, Harlow.
- Litman T. 2012, *Evaluating Public Transit Benefits and Costs*. Victoria Transport Policy Institute, www.vtppi.org.
- LMS 2012, Virtual.Lab online help.
- MSC.Software 2001, MSC.Nastran 2001: Superelement User's Guide.
- Prado M., Cunha R., Neto Á. 2001, *Bus Handling Validation and Analysis Using ADAMS/Car*. Proc. of the 16th European ADAMS User Conference 2001, Berchtesgaden, Germany, November 2001.
- Prochowski L., Żuchowski A. 2004, *Samochody ciężarowe i autobusy*. Wydawnictwo Komunikacji i Łączności, Warszawa.
- Svida D., Novotny P., Pistek V. 2007, *NVH Analysis of Tractor Cabin*. Proc. of XXXVIII. medzinárodná vedecká konferencia pracovníkov katedier a pracovísk spalovacích motorov vysokých škôl na Slovensku a Čechách, Bratislava, Slovakia, September 2007, pp. 231–238.
- WABCO 1997, *Elektroniczna regulacja poziomu (ECAS) dla autobusów z pneumatycznym układem zawieszenia*. <http://inform.wabco-auto.com>.