

ADAM MAREK

Influence of indirect frequency converters on operation of central leakage protection in underground coalmine networks

This paper presents considerations for leakage protections operating in underground coalmine networks containing loads that include frequency converters. The possibility of malfunctions in leakage protections has been proven in the case of a reduction of leakage resistance in a DC circuit.

Key words: central leakage protection (CZU), leakage resistance, capacitance to earth, indirect frequency converter

1. TYPICAL SOLUTIONS OF LEAKAGE PROTECTIONS

The leakage protections commonly used in Polish underground coal mines ($f_n = 50$ Hz) can be divided into protections based on constant and alternative auxiliary sources. The task of these leakage protections is to switch off the damaged fragments of a network and loads (or to signal such situations) in the case of a decrease the leakage resistance below the threshold value, which are specified by the relevant standards. The leakage protections available on the market are based on a constant auxiliary source. Protections based on direct auxiliary voltage as well as protections based on a direct auxiliary current are used.

Regardless of whether the measured magnitude is the current or the voltage, information about the condition of isolation is obtained through a comparison of the measured voltage to the reference value of the voltage (corresponding to the actuation of the threshold resistance of the leakage protection). In leakage protections based on direct auxiliary voltage (Fig. 1), it is voltage drop u_b along shunt R_b , and the value of leakage resistance R_d is described by the following dependence:

$$R_d = \frac{E_p}{U_b} R_b - (R_{p1} + R_{p2} + R_b + R_{dl}) \quad (1)$$

where:

- R_d – value of equivalent leakage resistance [W],
- E_p – value of auxiliary source voltage of leakage protection [V],
- U_b – average value of measured voltage along shunt R_b [V],
- R_b – value of measured shunt resistance [W],
- R_{p1}, R_{p2} – value of series resistances of leakage protection [W],
- R_{dl} – value of equivalent resistance of series reactor [W].

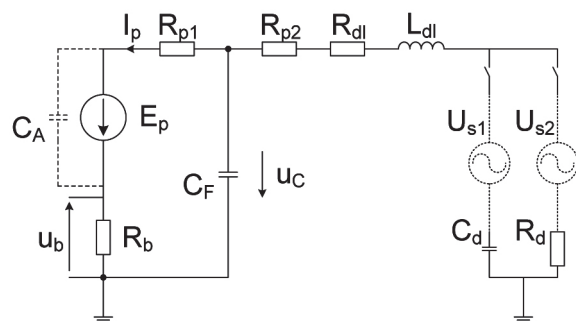

Fig. 1. Simplified equivalent circuit diagram of leakage protection based on direct auxiliary voltage

A simplified equivalent circuit diagram of the leakage protection based on direct auxiliary voltage also includes elements filtering the measuring voltage

waveform (filter capacitance C_F , C_A , and series reactor inductance L_{dl}) and other equivalent parameters of the controlled network: equivalent capacitance to earth C_d and equivalent interference voltage (associated with the asymmetry: network capacitance to earth U_{s1} and network leakage resistance U_{s2}).

In the case of leakage protections based on direct auxiliary current, two solutions are mainly used: leakage protections operating in an arrangement of a series-connected ohmmeter (Fig. 2) and leakage protections operating in an arrangement of a parallel-connected ohmmeter (Fig. 3). In the first solution, measurement magnitude is voltage u_p , which is measured across terminals of an equivalent auxiliary current supply. The network insulation condition is described by the following dependence [1]:

$$R_d = \frac{U_p}{I_p} - (R_{b1} + R_{b2} + R_{dl}) \quad (2)$$

where, in comparison to the previous circuit, the following magnitudes have appeared:

- R_{b1}, R_{b2} – resistance values of diode protective barrier [Ω],
- U_p – average value of measuring voltage of leakage protection [V],
- I_p – value of auxiliary current of leakage protection [A],
- C_A, C_F – values of filtering capacitors of leakage protection [F].

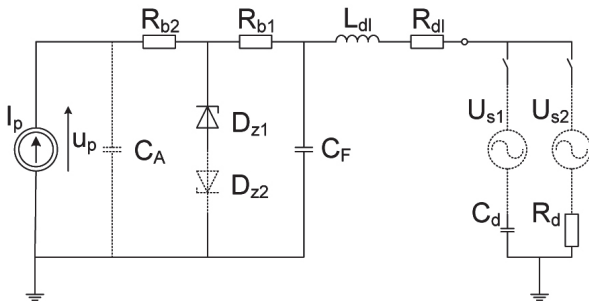

Fig. 2. Simplified equivalent circuit diagram of leakage protection operating in arrangement of series-connected ohmmeter based on direct auxiliary current

The second variant of the leakage protection based on a direct auxiliary current (in an arrangement of a parallel-connected ohmmeter) assumes that the voltage measurement is obtained by the passage of a current through measuring resistor R_V , which is connected in parallel to the auxiliary current supply

(Fig. 3). The presented solution allows us to preserve greater sensitivity in a range of resistances that are significant in the case of the correctness actuations of the leakage protection (about 2 to 3 times less than the adjusted resistance values of the leakage protection) and less sensitivity in a range of larger resistance values (a limitation of the maximum measuring voltage value).

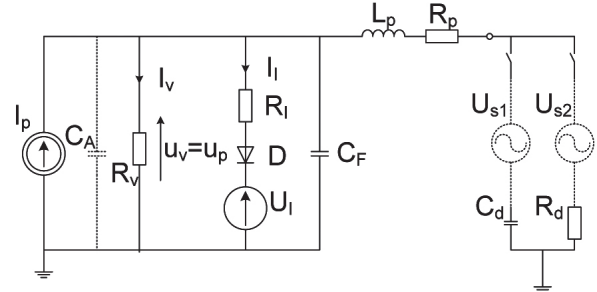

Fig. 3. Simplified equivalent circuit diagram of leakage protection operating in arrangement of parallel-connected ohmmeter based on direct auxiliary current

The value of the measured leakage resistance of the controlled network for leakage protection operating in an arrangement of a parallel-connected ohmmeter based on direct auxiliary current evaluated with greater sensitivity (without taking into account resistance R_V) is described by the following dependence [2]:

$$R_d = \frac{R_V}{\frac{I_p}{U_p} R_V - 1} - R_p \quad (3)$$

where, compared to the previous circuits:

- U_p – average value of measured voltage of leakage protection [V],
- R_V – value of parallel resistance of leakage protection [Ω].

The leakage protection based on the direct auxiliary current (regardless of whether they operating in an arrangement of a series-connected or parallel-connected ohmmeter) is not suitable for the detection of emergency conditions appearing in the DC current circuits. The cause of this state of affairs is a lack of opportunities for the correct measurement of the leakage resistance in both directions of the fault current.

Apart from the leakage protections based on direct auxiliary sources, there are also devices based on alternating auxiliary voltages. Available on the market are (or were) solutions based on a rectangular

(Fig. 4) or triangular alternating auxiliary voltage. By changing voltage polarity E_p periodically, two values of voltage U_b on measuring resistor R_b are obtained. The average value of the difference between these voltages U_{bAV} is lacking influences of the interfere voltage of DC circuit U_o . Under these conditions, the value of the measured leakage resistance described is the same relationship as in the case of leakage protections based on direct auxiliary voltage:

$$R_d = \frac{E_p}{U_{bAV}} R_b - (R_{p1} + R_{p2} + R_b + R_{dl}) \quad (4)$$

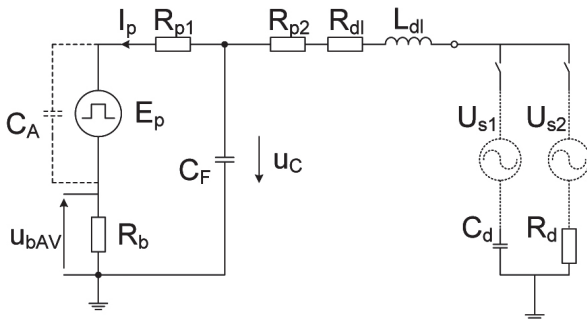

Fig. 4. Simplified equivalent circuit diagram of leakage protection based on alternating rectangular auxiliary voltage

The frequency of such an alternating auxiliary voltage cannot be too big due to the appearing transient states during changes in the polarity of the voltage. The time constant of the commutation circuit depends on the equivalent capacity, resistance, and inductance of the system (the resonant circuits can also appear). RC circuits in a steady state are achieved after a period of more than four times constants. In a typical coal mine environment, the period of auxiliary sources should not be less than about 3s. Taking into account the applicable standard, this is an important defect in this type of leakage protection solution. Apart from this fact, leakage protection based on alternating auxiliary voltage can correctly detect cases of a decrease in the leakage resistance in networks with indirect frequency converters.

A further analysis of the leakage protection cooperation with networks loaded by indirect frequency converters will focus on leakage protection based on direct auxiliary voltage. This type of leakage protection can work in both directions of current (changing the direction of the flowing current measurement can be caused by decreased value of leakage resistance in the DC circuit). The appearance of the additional direct voltage in the measuring circuit will probably

cause an erroneous result (measuring) in the value of the resultant leakage resistance. So, it is necessary to specify which effects will cause the emergence of an additional constant parasitic voltage on the operation of the leakage protection. This problem can be solved by the application of leakage protection with a rectangular shape of the auxiliary voltage with a lesser frequency than the minimum output frequency inverter in the case when the measurement would be operating in both directions of the auxiliary voltage.

2. INFLUENCE OF INDIRECT FREQUENCY CONVERTER ON OPERATING LEAKAGE PROTECTION

The technological progress in the field of power electronic valve production, power electronic development, and methods of controlling power electronic valves has influenced the more and more frequent application of power electronic converters (mainly rectifiers and frequency converters) to feed various loads; this is also true in underworld coal mine networks. In such a situation, the leakage protections should prove the effectiveness of the actuations not only in an alternating coal mine voltage network (input of the indirect frequency converters), but it should also detect decreasing leakage resistance in the indirect circuits of frequency converters (DC circuits) as well as at the outputs of indirect frequency converters (output of the inverters). Taking into account the fact that the leakage protections are most-commonly installed in transformer stations, these devices should detect decreasing leakage resistance: in a coal mine network, in an indirect circuit of a frequency converter, and at the output of the inverter (Fig. 5).

Figure 6 shows the equivalent scheme that includes the indirect frequency converter connected to the power coal mine network and leakage protection that should be controlling the state of isolation of the whole network (also with a frequency converter). This scheme takes into consideration the most-important parameters of the controlled parts of the network (before the frequency converter, in the indirect DC circuit, and at output of the frequency converter), as well as the parameters of the same leakage protection based on direct auxiliary voltage. The assumption was made that an analysis of the detection capability (by leakage protection) of leakage resistance decreases in different parts of the network with frequency inverters that will be carried out separately.

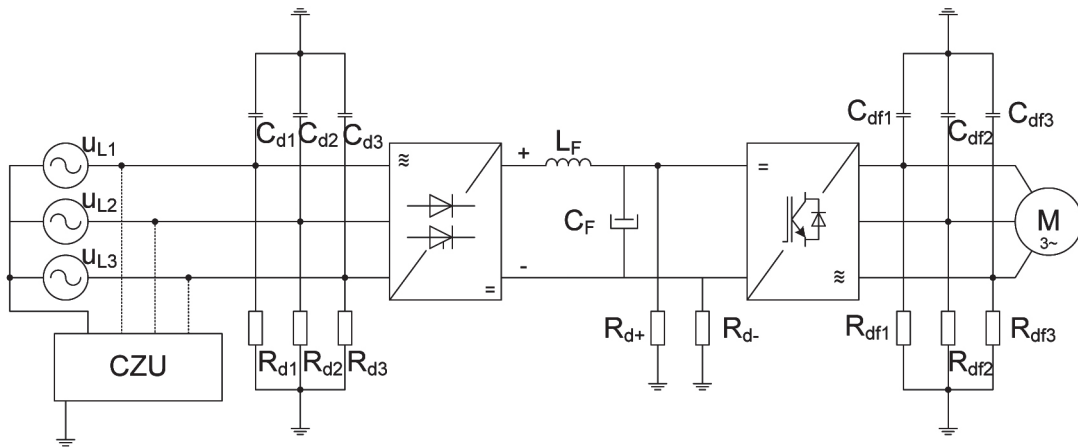

Fig. 5. Simplified diagram of equivalent part of network with leakage protection and with frequency converter supplying induction motor [4]

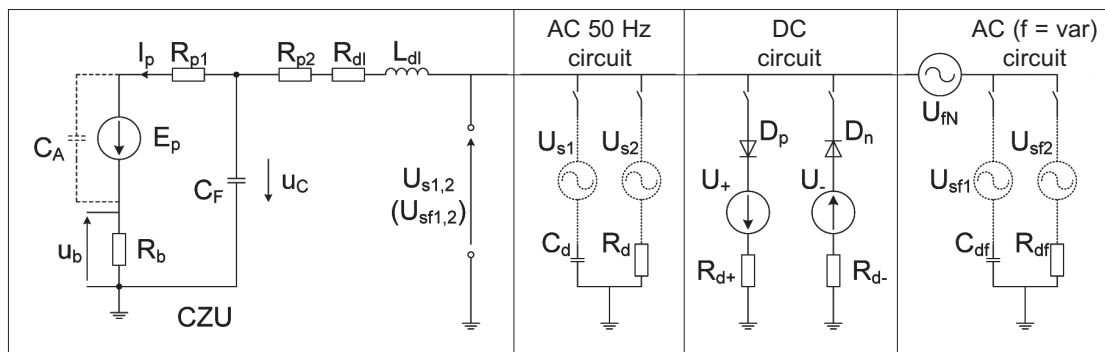

Fig. 6. Simplified diagram of equivalent leakage protection and power supply network with frequency converter, with taking into account independent, potential places of emergency or interference states

The frequency converter has no effect on the detection of the state of the decreased leakage resistance in a controlled part of an alternative coal mine network (while maintaining perfect insulation in the indirect circuit and at the output of the converter). The network isolation status is then described using dependence (1). The following impact the determination of the actual value of the leakage resistance (by measuring the unit of the leakage protection): the state of the symmetry of the network parameters to earth and the values of the capacity to earth and leakage resistance. Depending on whether we examine the influence on leakage resistance or capacity to earth for the correct actuation of the leakage protection, the consistency of the capacity to earth or leakage resistance is assumed. The RMS value of the interference voltage (for single phase decreasing of the leakage resistance) can be specified using dependence [3]:

$$U_{s1,2} \approx \frac{U_f}{\sqrt{1 + \frac{R_d^2}{X_{dz}^2}}} \quad (5)$$

The leakage protection shouldn't have any problems with the correct detection and actuation in the case when the leakage resistance is less than the threshold resistance at the output of the inverter. Depending on the actual output frequency of the inverter, a delay could appear in detecting such a situation (a lag of even several seconds) compared to an instance of decreasing leakage resistance in an underworld coal mine network. Ignoring the additional resistance between the input of the frequency inverter and load (they are small compared to the rest of the resistance of Fig. 1), relationship (1) can also be used to describe the network insulation status at the output of the inverter. Analogously, the value of the RMS interference voltage at the output of the inverter can be determined (for the single-phase reduction of the leakage resistance) [3]:

$$U_{sf1,2} \approx \frac{U_{ffal}}{\sqrt{1 + \frac{R_{df}^2}{X_{dzf}^2}}} \quad (6)$$

where U_{ffal} – RMS value of output phase voltage of inverter [V].

A serious influence on the proper function of the leakage protection may have a reduction of the leakage resistance in the DC circuit of the frequency converter (Fig. 7).

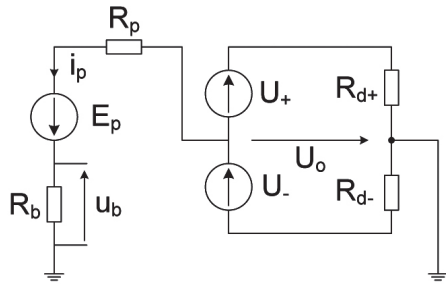

Fig. 7. Simplified, equivalent diagram used to define influence DC circuit of frequency converter on operating leakage protection

A particularly unfavorable situation occurs when $E_p = U_o$. It may prevent the detection of an earth fault: in the DC circuit or at the output of the inverter. The measured quantity of the leakage protection based on direct auxiliary voltage is the average value of measuring current I_p . Information about this current is achieved on the basis of the average value of voltage drop u_b along shunt R_b [4]:

$$U_b = \frac{R_b}{R_b + R_p + \frac{R_{d-} \cdot R_{d+}}{R_{d-} + R_{d+}}} \left(E_p - \frac{U_d}{2} + \frac{U_d}{1 + \frac{R_{d-}}{R_{d+}}} \right) \quad (7)$$

For a 1000 V alternative underworld coal mine network, the value of the response threshold resistance of the leakage protection is 30 k Ω . Measured voltage U_b along shunt R_b (with which the leakage protection based on direct auxiliary voltage should actuate at the 1000 V network) is described by relation [1]:

$$U_{b30k} = \frac{R_b}{R_b + R_p + R_{d30k}} E_p \quad (8)$$

Characteristics of voltage U_b along shunt R_b (indirectly, also the average value of measuring current I_p) depending on the changes in the leakage resistance of the rods in the DC circuit were obtained based on relationships (7) and (8). The following were presupposed in the calculations: $E_p = 100$ V, $R_p = 199$ k Ω , $R_b = 1$ k Ω , $U_d = 1350$ V. First was shown the dependency of measuring voltage U_b as a function of chang-

es in the leakage resistance value of negative rod R_{d-} and parametric ($R_{d+} = 1, 30, 100, 500, 1000$ k Ω) changes in the leakage resistance values of positive rod R_{d+} (Fig. 8).

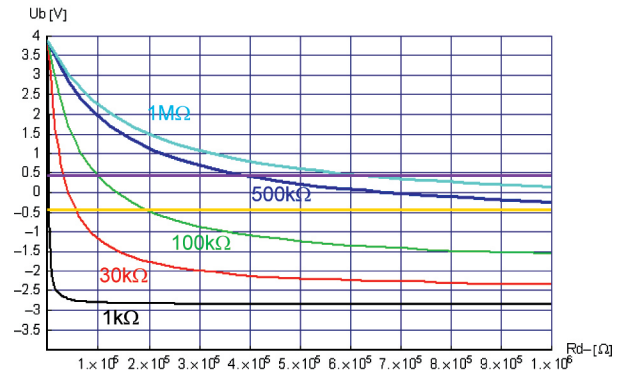

Fig. 8. Dependencies of average value of measuring voltage U_b along shunt R_b in function of changes in leakage resistance of negative rod R_{d-} and parametric changes in resistances of positive rod R_{d+}

The obtained results indicate that malfunctions can appear during operation of the leakage protection: the leakage protection doesn't actuate, despite the fact that the conditions for its actuation were fulfilled (-0.435 V $< U_b < 0.435$ V), and instances of unnecessary actuations of the leakage protection may also arise ($U_b < -0.435$ V and $U_b > 0.435$ V). The area of leakage resistance values of both rods in a DC circuit where the appearance of an incorrect actuation of the leakage protection may emerge is small, and it is related to similar leakage resistance values of both rails in a DC circuit.

The possibilities of the emergence of cases of unnecessary actuation of the leakage protection can appear more often. The situation is particularly bad for the leakage resistance of positive rod R_{d+} , which contain between 30 k Ω and about 200 k Ω (for example, for leakage resistance of positive rod $R_{d+} = 100$ k Ω , the leakage resistances of negative rail R_{d-} containing between 30 k Ω and 90 k Ω and above 200 k Ω will lead to unnecessary actuations of the leakage protection).

The following charts (Fig. 9) indicate that parametric leakage resistance reduction in negative rail R_{d-} contributes to the same negative phenomena, but in an even wider range of the leakage resistances than was the case for the previously analyzed situation (for example, for the leakage resistance of negative rail $R_{d-} = 100$ k Ω , the leakage resistance values of positive rail R_{d+} above 100 k Ω will lead to the unnecessary actuation of the leakage protection).

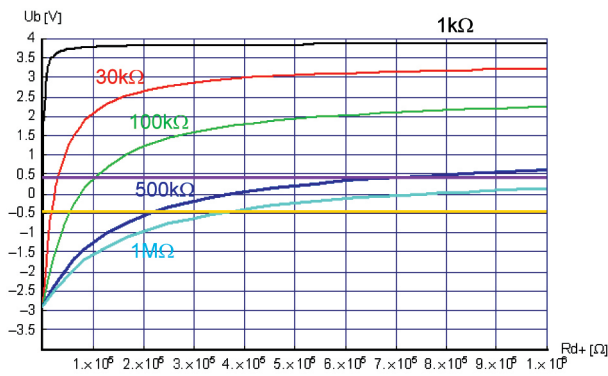

Fig. 9. Dependencies of average value of measuring voltage U_b along shunt R_b in function of changes in the leakage resistance of negative rod R_{d+} and parametric changes in resistances of positive rod R_{d-}

3. SUMMARY

Using frequency converters to supply the receivers contributes to changes in the operating conditions of leakage protection. Changes in the leakage resistance in DC circuits of indirect frequency converters have especially adversely affected the correct operation of the leakage protection based on the direct auxiliary source affected. These can lead to a lack of leakage protection actuation (despite the fact that there are conditions for its operation) and its actuation, in the case when the fulfillment conditions are not met for doing so. The carried-out analysis indicates that the leakage protection based on a direct auxiliary source in specific situations will not work properly (Fig. 8 and 9). Resistance to a decrease in leakage resistance R_d in the DC circuits should be checked in order to limit the cases of leakage protection malfunction (manufacturers may apply additional solutions that reduce this type of incorrect actuation).

These sorts of issues should not arise when frequency converters are used in the standard version (the whole converter is located in a single case), in which only the input terminals for the connection to an underworld coal mine network (input rectifier) and output terminals for connecting to the receiver (output of the inverter) are available. However, the situation where the rectifier of the frequency converter

is located in a place other than its inverter is becoming more and more frequent; therefore, the output of the rectifier is connected by using cables with input terminals of the inverter [5]. In the case of such an occurrence, application of the leakage protection is necessary in order to correctly detect the decrease of leakage resistance R_d in the DC circuits.

When there are no adverse effects of the DC circuits, the leakage resistance measurement in an underworld alternating coal mine voltage network does not differ substantially from the situation when there are no frequency converters. However, it should be noted that the frequency of the output voltage of the inverter is variable, depending on the required operating state of your receiver (under these conditions, it influences the response time of the leakage protection and substitute capacitance of the network).

Leakage protections based on alternating auxiliary voltages allow for avoiding the negative effects associated with a reduction of leakage resistance in the DC circuits. However, such arrangements need longer response times to actuate in the case of a reduction in the leakage resistance below the threshold resistance of the leakage protection.

References

- [1] Marek A.: *Wybrane zagadnienia centralnych zabezpieczeń upływowych z pomocniczym źródłem prądowym*, Konferencja EMTECH 2014: 82–91.
- [2] Marek A.: *Właściwości centralnych zabezpieczeń upływowych w układzie omierza równoległego z pomocniczym źródłem prądowym*, XV Krajowa Konferencja Elektryki Górniczej 2014: 161–171.
- [3] Marek A.: *Zabezpieczenia upływowe w sieciach z przemiennikami częstotliwości w podziemiach kopalń*, "Mining – Informatics, Automation and Electrical Engineering" 2010, 2: 30–35.
- [4] Marek A.: *Analiza przydatności wybranych zabezpieczeń upływowych w dołowych sieciach z przemiennikami*, Konferencja EMTECH 2016: 64–72.
- [5] Elgór + Hansen: *Układ zasilania z wykorzystaniem przesyłu energii prądem stałym*, product's card.

ADAM MAREK, Ph.D., Eng.
 Department of Electrical Engineering
 and Industrial Automation
 Faculty of Mining and Geology
 Silesian University of Technology
 ul. Akademicka 2, 44-100 Gliwice, Poland
 Adam.Marek@polsl.pl