

ZYGMENT ZUSKI

The creation of a new transportation route near the Crystal Grotto in the “Wieliczka” Salt Mine through the construction of a fore-shaft equipped with a transportation device

This article presents the planned fore-shaft construction between the 2nd upper and 2nd lower levels equipped with a hoisting device for materials transportation. The main aim of this venture was to create a means of transporting materials used in the process of protecting and maintaining the Crystal Grotto. There is currently no vertical connection between the 2nd upper and 2nd lower level. As a result, all material transportation is performed manually over the incline paths.

Key words: *fore-shaft, construction, pit, vertical transport*

1. HISTORICAL BACKGROUND

The area covered by the construction plan was excavated for the first time in the 17th and 18th centuries. When the “Wieliczka” Saltworks company was taken over by the Austrian occupying powers, intensive exploration and exploitation was focused in the northeast region of the mine and a shaft type deposit of salt. Classical longitudinal based drilling with a levelled corridor and simple techniques was initiated at the turn of the first and second decade of the 19th century in what became known as the Baum part of the mine. After 1824, the traditional excavations were stopped for several years and the focus was placed on the recognition and exploitation of the shaft salt deposit which was located in the top part of the Crystal Grotto dome.

Until 1856, when the connection of the Baum Chamber with the Leopold-Münch Canal was created, the Baum longitudinal was the only communication and transportation route leading to exploitation works in the top part of the Crystal Grotto dome. The importance of the gallery decreased in the 1870s, when salt exploitation from this part of the deposit was ended [1]. After World War II, communication with this area was only possible from the 3rd level via the Leopold-Münch Canal or from the 2nd level through the Schwind traverse.

2. TECHNICAL CHARACTERISTICS OF THE FORE-SHAFT AND AIM AND SCOPE OF PLANNED WORKS

The fore-shaft that will be created near the Crystal Grotto is supposed to connect the 2nd upper level with the 2nd lower level. This will also serve as the way for maintenance materials to be transported to these excavations (the group of chambers is as follows: Baum, Schmidt and Ferro, Ksawer, Leopold, Schwind).

Currently, the only existing connection between the material shaft and the Crystal Grotto is via the infrastructure on the 3rd level which means that all materials once transported to the 3rd level are moved from this region of the mine through the Schwind fore-shaft to the 2nd lower level. Further information about equipping the Schwind shaft with a transportation device was presented in the journal “Mining Informatics Automation and Electrical Engineering” nr 2(538) 2019 [2]. As there is no further connection between 2nd lower level and 2nd upper level, the transport of materials is taking place manually and in a limited way, with miners using existing incline corridors for that purpose.

The designed fore-shaft, with a depth of approx. 22.4 m, will connect the 2nd upper level and 2nd lower level with a transportation device enabling the mechanical transport of maintenance materials to described area of the Salt Mine – from the Schwind shaft

and crossbar Schwind through the planned fore-shaft at the 2nd upper level to the longitudinal Baum and then to direction where all mining jobs based on the reinforcement of the Crystal Grotto are taking place.

This is the next stage of the process aiming at mechanizing the transportation of materials between the 2nd upper level and the 3rd level in the region of the mine that covers the Crystal Grotto. The main materials to be transported are: sawn timber, including sawn timber with a length of up to 6 running meters, and bagged loose materials.

Technical data of the fore-shaft:

- Location: eastern part of “Wieliczka” Salt Mine.
- Function: transportation fore-shaft.
- Size: depth of 22.4 m.
- Cross-section: rectangular with size of 3.05 m × 1.8 m.
- Equipment: transportation compartment, ladder compartment.

3. CHARACTERISTICS OF THE GEOLOGICAL, NATURAL, AND MINING CONDITIONS

3.1. Geological structure of the orogen surrounding the shaft

The deposit in the analysed part of the rock mass takes the form of a structure known as the dome of

the Crystal Grotto (Fig. 1). It is an anticlinal elevation, on the northern slope of which there is situated a natural object from which the name of the Crystal Grotto derives. On top of the formation of sub-salt which has formed an anticline (known as the Skawina Formations, the salt has created a bedded deposit, with a block deposit of salt on top of this.

The salt rocks are separated from the aquifers by secondary clay-gypsum cover. The overburden consists of the Chodenickie Formation lying over the northern slope of the dome. They are important due to the water hazard in the analysed excavations of the salt mine.

The entire complex is covered with Quaternary formations formed of post-glacial clays with inserts of water-logged dust, sand and gravel.

The analysed excavations of the 2nd upper and 2nd lower-level cut through the bedded deposit formations. Bronze salts, shaft salt and seam green salts are exposed in them, with one of the seams creating rubble containing lumps of the oldest salts. Under the seams of green salts there is so-called sub-salt sandstone, which is a conglomerate of sandstone, mudstone and claystone with a WT3 tephrite insert.

Water deposits from the Skawina Formation, which is part of the residual formations, are in the process of leaching in the area under the Crystal Grotto [3].

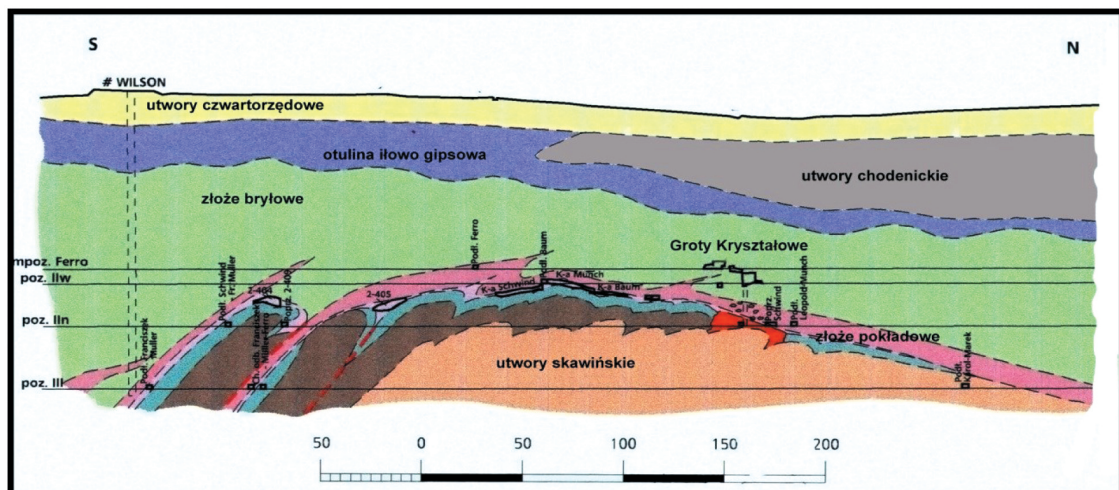

Fig. 1. Cross-section through the dome of the Crystal Grotto [3]

3.2. Projected shaft profile

The bottom of the Baum longitudinal in the analysed area is situated at a depth of about 172.5 m above sea level, and the bottom of the Schwind transverse at a depth of about 150.1 m above sea level. Therefore, the designed shaft will be approximately 22.4 m deep,

and formations of the bed deposit should be expected from the height of the Baum longitudinal to the height of the Schwind transverse.

In the Baum longitudinal, bronze salts with intergrowths of gangue anhydrite-claystone with a thickness between several and dozen centimetres have been exposed.

Below the Baum longitudinal (about 1 m), there is a shaft salt seam which was mined by the Baum Chamber. This seam is approximately 1–1.2 m thick.

Shaft salt is situated on bedded green salts. They form a complex with a thickness of about 5–7 m. The last, lowest layer of green salt in the profile is formed in the form of rubble and residual formations created as a result of the leaching of the deposit with waters from sub-salt formations.

3.3. Hydrogeological conditions in the analysed region

The Baum longitudinal and the Schwind transverse in the area of the planned shaft are classified as the 1st degree of water hazard. The final, eastern section of the Baum longitudinal, about 30 m long, has been classified as the 3rd degree of water hazard, as is the final, northern section of the Schwind transverse. These excavations were made in bedded deposit formations – seabed green salts, shaft salts and bronze salts.

The Baum longitudinal and the Schwind transverse are located within a structure called the dome of the Crystal Grotto. Due to the presence of water in the Skawina Formation found in the vicinity of the analysed area, there is a probability of water appearing under pressure during the execution of the works.

The planned shaft with a depth of 22.4 m will intersect the formations of the bedded deposit – bronze salts, shaft salts and green bedded salts. The brine migrates along the intergrowths of the gangue within the salt, so there is a possibility that there will be small inflows of water during the construction of the shaft. This will be related to leaks recorded in the immediate vicinity and other observed water phenomena.

3.4. Natural values of the analysed region

The area of the planned shaft is protected in the form of:

- buffer zones of the Crystal Grotto nature reserve,
- documentation stations.

The nature reserve was established by *Regulation No. 84/2000 of the Lesser Poland Voivode of September 11, 2000* (announcement in the Official Journal of the Lesser Poland Province No. 77, item 711, September 29, 2000). According to the regulation, the

reserve includes Lower Crystal Grotto (706 m³) and Upper Crystal Grotto (1000.17 m³) together with their surroundings in a block with a base of 10,400 m² and a height of 44 m, reaching from the second lower level of the mine to 20 m above its second upper level.

In addition, the ordinance established the underground and above-ground buffer zone of the reserve.

The network of documentation sites of inanimate nature was established by *the Ordinance of the Krakow Voivode No. 10 of June 6, 1997 on the legal protection in the form of documentation sites of geological objects in the Wieliczka Salt Mine* (announcement in the Official Journal of the Krakow Voivodeship No. 21, item 119, of July 1, 1997).

The Baum longitudinal at the second upper level is included in the documentation site No. 35.B/19.

The Schmidt crossbar at the second lower level is included in the documentation site No. 35.B/22.

The content of the above ordinances shows that all mining works designed and carried out in the analysed excavations require the approval and permission of the relevant services of the voivode as the planned works not only relate to the protection of monuments, but also to the protection of the environment.

Due to the natural and geological values of the area where the works will be carried out, the contractor should bear in mind that if any signs of secondary crystallization of halite are encountered during the drilling of the shaft, the works must be immediately stopped and the geological service of the mine notified.

3.5. Existing area of planned works

In the area of the planned works at the second upper level, the longitudinal Baum is made in a rectangular section in a wooden casing, consisting of single arches and a lining of floorboards, the width of the longitudinal is approximately 1.3 m, and the spacing of the arches is approximately 0.5 m (Figs. 2 and 3).

At the second upper level, the projected ventilation shaft will pass through the void of the Baum Chamber (Fig. 4), piercing the chamber's ceiling and floor at the southern abutment of the pillar. In the area of penetration through the chamber floor, there is a layer of loose debris estimated to be approximately 1 to 1.3 m thick. Local disintegration of limestone and evident squeezing of the chamber are present in the chamber ceiling. Due to the poor technical condition of the chamber, protective works are being conducted, including the construction of wooden casings.



Fig. 2. Baum longitudinal. The area of the planned shaft. Exposure of bronze salts with intergrowths of anhydrite claystones. As of July 2017 [4]

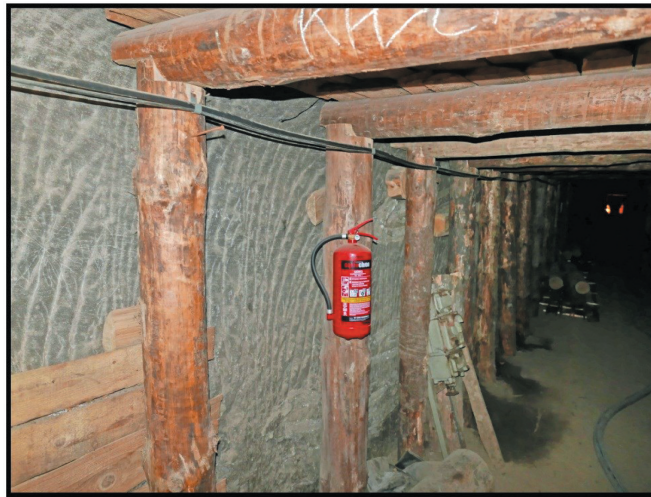

Fig. 3. Baum longitudinal. The area of the planned shaft. Exposure of spizium salts. As of July 2017 [4]



Fig. 4. Baum Chamber. State as of November 2018 [4]

At the planned work area on second lower level, the cross-section of the Schwind traverse is rectangular and enclosed in a wooden casing. The casing consists of individual doorframes and linings made

of boards from the ceiling fields and partially from the abutments. The transverse width is approximately 1.5 m, and the spacing between doorframes is about 1.0 m (Fig. 5).



Fig. 5. Schwind Transverse. Area of the planned ventilation shaft. State as of July 2017 [4]

4. TECHNICAL CHARACTERISTICS OF THE PROJECTED FORE-SHAFT

4.1. Location of the projected fore-shaft and connecting excavations

The planned shaft, with a depth of 22.4 m, vertically connects the second higher level to the second lower level. It is located in the eastern part of the mine, at the intersection of the Baum longitudinal trace at second upper level and the Schwind transverse trace at second lower level, situated between levels 2nd upper and 2nd lower of the Baum and Ferro chambers. The shaft is situated outside the boundaries of the Crystal Grotto nature reserve within the buffer zone of the reserve.

At 2nd upper level, the shaft's headframe and the connecting drift to the Baum longitudinal drift, running north south direction with a length of approximately 10.7 m, are located above the Baum Chamber's pillar.

Also, below the Baum Chamber at 2nd lower level, the shaft's bottom frame and the connecting drift to the Schwind transverse drift were located, running north by northwest and south by southeast with a length of about 20.3 m. A ventilation airlock with board doors and a temporary storage area for materials is planned in the drift connecting the bottom frame with the Schwind transverse drift. The location of the fore-shaft and connecting drifts to the existing workings is shown in Figure 6.

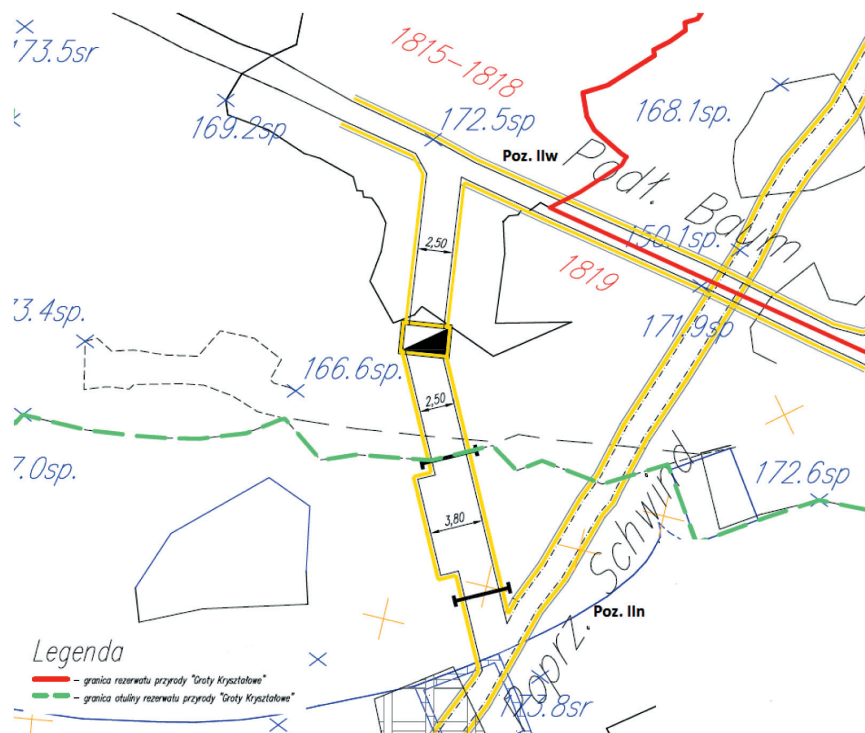

Fig. 6. Layout of the planned excavations

4.2. Shaft headframe

The projected shaft headframe has a rectangular cross-section with dimensions of 3.05 m by 1.80 m.

The shaft headframe includes a transport compartment and a ladder compartment for monitoring the shaft casing. The ladder compartment elements will be made of composites and stainless steel, with installed cables and power, control, and signaling lines. The shaft casing will be wooden and crown-shaped. The shaft headframe is shown in Figure 7.

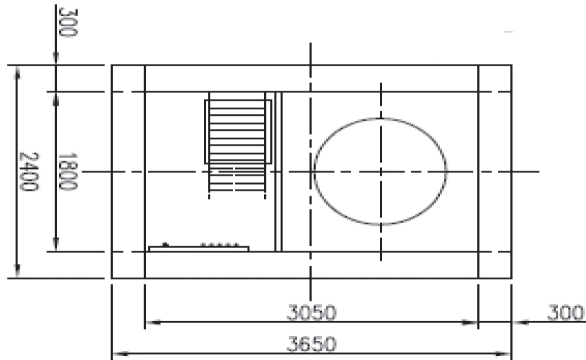

Fig. 7. Shaft headframe

4.3. Shaft casing

The shaft casing is designed as a wooden frame (crown-shaped) made of solid pine beams. The crown elements will be made of rectangular beams with dimensions of 0.2 m × 0.3 m (height × width). The beams will be joined in the corners using carpentry joints with overlapping straight joints and reinforced with carpentry clamps driven from the outside of the beams to add stability. The void space between the wooden casing and the shaft will be filled with debris to stabilize the crown elements.

At the section where the shaft passes through the Baum Chamber, the chamber's ceiling and abutment will be secured with a full wooden casing made of spruce beams with a square cross-section of 0.2 m × 0.2 m. The casing will be placed on a levelled and cleaned limestone bed. It is estimated that approximately 1.0–1.3 m of loose debris will be present on the chamber's floor in the area of the planned works.

The shaft openings will be designed as closed truss frames made of wooden beams with a cross-section of 0.3 m × 0.3 m. To stabilize the shaft casing, three feet with extended crown beams are planned. The ends of the feet beams should be placed on a levelled concrete bed made of C20/25 concrete. Approximately 15 centimetres of space should be left between the

front of the beams and the shaft void. The top foot should be built on the levelled and cleaned floor of the Baum Chamber.

The shaft casing structure and elements with the openings are presented in Figure 8.

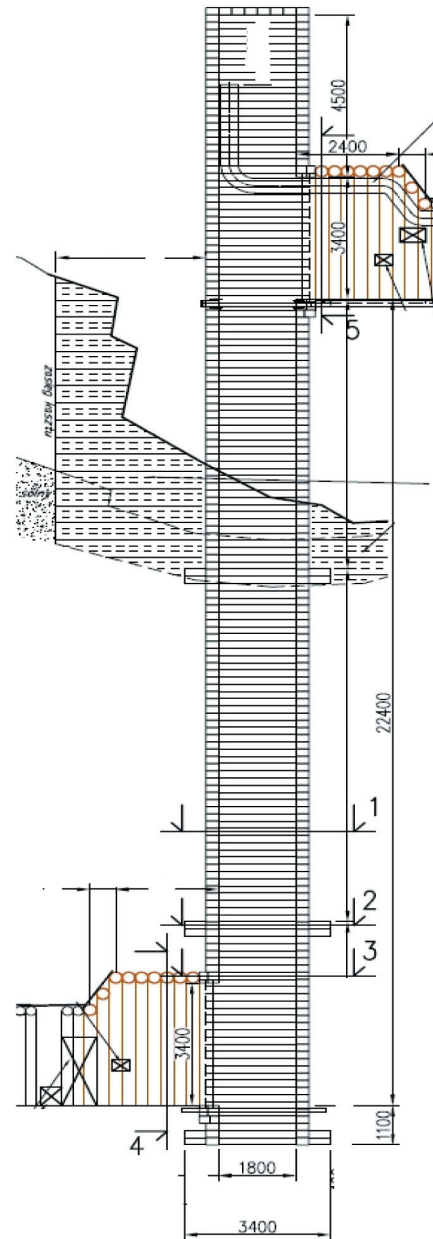

Fig. 8. Vertical cross-section of the shaft

5. EQUIPMENT OF THE FORE-SHAFT

5.1. Ladder compartment

The fore-shaft is equipped with a ladder compartment allowing for technical inspections and passage between the 2nd lower and 2nd upper levels. The components of the ladder compartment will be made of composite materials [5], such as EVER P and

EVER K. All steel elements of the ladder compartment will be made of stainless steel (grade A4 according to norm 1.4401) [6], including small connecting elements such as screws, fixing anchors, and guide brackets. This ensures that the ladder compartment will be entirely resistant to corrosion. The ladder compartment consists of a resting platform for relaxation during passage and allows individuals to transfer from one ladder to another. The platform has drain holes to prevent water accumulation, and its surface is non-slip. The resting platform is fixed to the shaft casing using channels attached to the casing with stainless steel elements. This frame also serves as a support for the ladder and the installation of a partition that separates the ladder compartment from other parts of the shaft, protecting individuals passing through the ladder compartment from falling into the shaft. The partition netting is attached to the end frames using specially prepared stainless-steel brackets to prevent it from deviating beyond the outline of the ladder compartment structure. The fixed ladder is immobilized at both ends by screw connections through suitable stainless-steel brackets, ensuring its stability during movement. Ladder rungs are welded to the stringers on both sides, providing a secure connection. The selected elements used in the ladder compartment's construction allow for quick replacement without the need for welding techniques. The ladder compartment elements meet the requirements of the *Minister of Energy's Regulation of November 23, 2016, regarding specific requirements for underground mining plant operation* [7] and strength requirements according to norm PN-G-46222 [8].

5.2. Transport compartment

The transport compartment is designed for material transportation, primarily lumber, including boards with lengths of up to 6 meters, and bagged bulk materials. The load capacity of the transport device is 10 kN.

Materials can be transported in a chain-driven transport basket without guiding. A wire hoist is provided for moving the basket. In the case of long materials with dimensions exceeding the basket's size, they can be directly transported using a suspension on the hoist hook.

At the bottom and top of the bottom frame and top frame, access to the transport compartment will be secured with gates on each level.

During the transportation of long materials, it is prohibited for the operators to be in the shaft at the

2nd lower level. Workers at the 2nd upper level must always use fall protection equipment, such as safety harnesses attached to fixed structural elements, with safety lines and shock absorbers.

5.2.1. Transport basket

The basic elements of the transport basket shown in Figure 9 include: the transport platform (1), four sets of chain pull rods (5), securing chains (7), the frame traverse with a protective roof (2), and four-rope chain suspension (6). The basket is suspended on a swivel bearing (8) on the hoist hook (4).

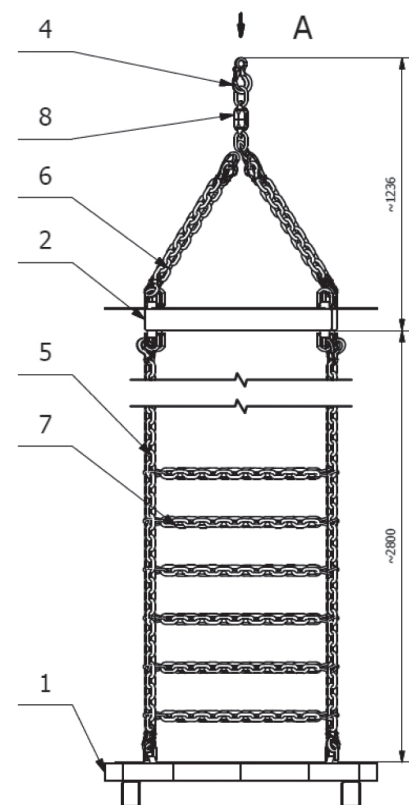

Fig. 9. Transport basket

5.2.2. Transport hoist

The main operational element of the system is the wire hoist equipped with a 9 kW maximum power motor powered by 500 VAC voltage through a frequency converter. The hoist will also be equipped with the following additional elements:

- electromagnetic brake (HM1),
- external cooling (WM1),
- encoder (CEN),
- overload sensor (CPR),
- maximum rope extension sensor (CMR),
- minimum rope retraction sensor (CMZ).

Other elements of the system include:

- power and control distribution board (RZS1),
- operating control panel (PSOD),
- operating control panel (PSOG),
- junction box (SKP),
- audible warning signal (SOS1, SOS2),
- visual signal (SOP1, SOP2),
- shaft gate opening sensor (COWD, COWG),
- basket support extension sensor (COP),
- shaft gate latch (EZD, EZG).

The entire system is managed by PLC controllers placed in a RZS1 distribution board and SKP switching box. The input and output modules of the controller are primarily used to operate manipulators, buttons, switches, sensors, and indicator lamps, as well as to control the operation of the frequency converter powering the hoist motor through Ethernet communication.

The devices included in the designed system are controlled using the PSOD and PSOG operating control panels. The PSOD panel will be located at the 2nd lower level, while the PSOG panel will be at the 2nd upper level. Additionally, LCD displays are mounted on the facades of the PSOD and PSOG panels, showing information about the hoist operation, sensor status, and any system malfunctions. The LCD display communicates with the PLC controller via the RS-485 standard [9].

6. TRANSPORT SAFETY ELEMENTS IN THE FORE-SHAFT

To ensure the highest level of safety for transportation work in the ventilation shaft, the following safety elements have been implemented:

- fixed support for the transport platform at the 2nd lower level and extendable support at the 2nd upper level,
- roof above the transport platform,
- lockable shaft gates to the transport and ladder compartments,
- transport control system managed by a PLC controller,
- safety system lockouts for the hoist operation,
- it ensures the safety of the hoist operation through appropriate sensors,
- stationary lighting in the bottom and top frames of the shaft.

6.1. Lockouts

The hoist operation has been secured using specific sensors. The individual sensors and their functions are described in Table 1.

Table 1
Overview of hoist safety sensors

Sensor name	Sensor function	Remarks
Lower shaft gate opening sensor	Activating the sensor results in an immediate stoppage of the basket movement. Basket movement in any direction is not possible	Stopping the movement only in "with basket" mode
Upper shaft gate opening sensor	Activating the sensor results in an immediate stoppage of the basket movement. Basket movement in any direction is not possible	Stopping the movement only in "with basket" mode
Basket support extension sensor	Activating the sensor results in a stoppage of the upward basket movement	Stopping the upward movement in any operating mode
Overload sensor	Activating the sensor results in a stoppage of the upward basket movement	Stopping the upward movement in any operating mode
Maximum rope extension sensor	Activating the sensor results in a stoppage of rope extension	Stopping rope extension in any operating mode
Maximum rope retraction sensor	Activating the sensor results in a stoppage of rope retraction	Stopping rope retraction in any operating mode
Encoder sensor	The primary function of the encoder is to control the rotational speed of the hoist motor, ensuring it matches the desired speed. The secondary function is to control the direction of the hoist motor, ensuring it aligns with the desired direction. If the speed exceeds allowable values (e.g., motor overrun) or the direction does not match the intended direction (e.g., unintentional downward movement of the basket), the basket will stop. The encoder also continuously monitors the length of the rope extension	The sensor operates in any operating mode

7. CONCLUSION

With the construction of the transport shaft from the 2nd lower level to the 2nd upper level in the “Wieliczka” Salt Mine, a connection will be established between the 2nd upper and 2nd lower levels in the eastern part of the mine near the Crystal Grotto. This will provide a transportation route for materials required for securing the broader Crystal Grotto area (including the Baum, Schmidt, and Ferro chambers, Ksawer, Leopold, Schwind areas). Currently, the Kinga material shaft is the only connection to the Crystal Grotto area, and it is only accessible from level three. There is currently no direct connection between the 2nd upper and 2nd lower levels. The planned transport shaft, approximately 22.4 m long, will link the 2nd lower level to the 2nd upper level, providing a transportation route from the Schwind shaft to the Schwind transverse, then through the proposed shaft to the 2nd upper level and the Baum longitudinal section for mining operations aimed at securing the Crystal Grotto.

This project includes powering and controlling the hoist for material transportation in the Baum shaft. The implementation of this project will significantly improve safety in the mine workings and mining operations in the mentioned area. This will be achieved by:

- eliminating manual material transportation using inclined planes and stairs from the 2nd lower to 2nd upper level,
- mechanizing work processes,
- automating the control processes of the transportation device (hoist),
- implementing multi-level safety elements and lockouts for transportation work in the shaft.

Furthermore, the process of securing the Crystal Grotto area will be considerably expedited, contributing to the preservation of this unique natural reserve on a global scale. Additionally, the transportation costs from the 2nd lower and 2nd upper level will be reduced.

References

- [1] Charkot J., Skubisz M.: *Studium historyczno-konserwatorskie dla rejonu planowanego wykonania szybiku łączącego podłużnię Baum na poziomie IIw z poprzeczną Schwind na poziomie IIn w Kopalni Soli Wieliczka*. MZK Wieliczka, sierpień 2018.
- [2] Zuski Z., Pasek R., Rożenek Z.: *Equipping the Schwind shaft with transport device*. Mining Informatics Automation and Electrical Engineering 2019, 2(538): 33–38.
- [3] Brudnik K. *Przekrój przez kopulę Grot Krystalowych*. Archiwum działu Mierniczo-Geologicznego K.S. „Wieliczka” S.A., 2000.
- [4] Przybyło J.: *Dokumentacja fotograficzna wyrobisk podłużnia Baum, komora Baum, poprzecznia Schwind*. Archiwum działu Mierniczo-Geologicznego K.S. „Wieliczka” S.A., 2017–2018.
- [5] Zuski Z.: *Kompozyty – innowacyjne materiały dla górnictwa*. Szkoła Eksploatacji Podziemnej Międzynarodowa Konferencja Naukowa, Kraków 2021.
- [6] Fundacja Nauka i Tradycje Górnicze z siedzibą: Wydział Inżynierii Łądowej i Gospodarki Zasobami, Akademia Górniczo-Hutnicza w Krakowie: *Aktualizacja dokumentacji projektowej wykonania szybiku transportowego (wraz z dobudowaniami do szybiku górny i dolny) z podłużni Baum na poziomie IIw do poprzeczni Schwind na poziomie IIn kopalni wraz z jego wyposażeniem*. Kraków 2021 [unpublished].
- [7] *Rozporządzenie Ministra Energii z dnia 23 listopada 2016 r. w sprawie szczegółowych wymagań dotyczących prowadzenia ruchu podziemnych zakładów górniczych*. Dz.U. z 2017 r., poz. 1118 z późn. zm.
- [8] Polska Norma PN-G-46222: *Szyby górnicze – Przedziały drabinowe – Wymagania i badania*.
- [9] Biuro Studiów i Projektów Górniczych w Katowicach: *Projekt techniczny wykonania szybiku wraz z jego wyposażeniem z poz. IIw na poz. IIn; z podłużni Baum do poprzeczni Schwind w podziemnej części zakładu Kopalni Soli „Wieliczka”, nr proj. 31022*. Katowice 2018 [unpublished].

ZYGMUNT ZUSKI, M.Sc., Eng.

“Wieliczka” Salt Mine

Park Kingi 1, 32-020 Wieliczka, Poland

zygmunt.zuski@kopalnia.pl